

Escale Handwash basin

19033W

Product Description: Handwash basin with integral shroud and towel rail

Product Dimensions: W500 x D315 mm

Colour/Finish: White

Material: Fireclay

Product Weight (kg): 11

Fixings Included: Wall fixing and levelling kit

Guarantee (Years): 25

Additional Information: Rinse thoroughly and use a soft cloth to wipe the product dry after use. Soft abrasive cleaners may be used when necessary to clean vitreous china products. Strong abrasive cleaners will scratch and dull the surface. Wipe any splashes of cleaning solutions from plastic or plated surfaces immediately.



Dimensions (mm)

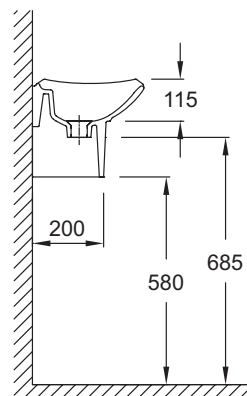
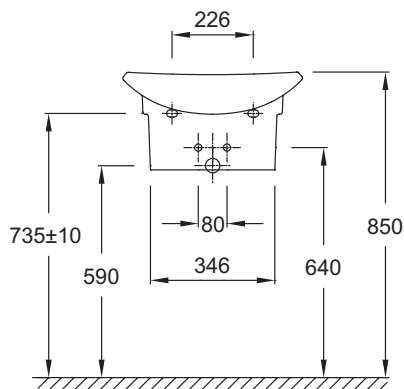
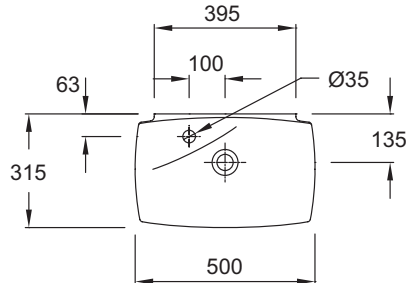

Kohler UK

Sales and Technical: +44 (0) 844 571 0048

info@kohler.co.uk

www.KOHLER.co.uk

THE BOLD LOOK
OF **KOHLER**®